

FULL FRAME

Single Frame
Single Glass

OPERABLE
GLASS





DETAIL SPECIFICATION

| Operation Methods | | Maximum Size | |
|------------------------|---|--------------|---------|
| | | Width | Height |
| Stacking System | | | |
| Ordinary | ✓ | 1200 mm | 4000 mm |
| Parallel | ✓ | | |
| Center | ✓ | | |
| Induction | ✓ | | |
| Folding | | | |
| Paired | ✓ | 800 mm | 3500 mm |
| Fold Side | ✓ | | |



Glass Thickness
 10 mm Non Tempered
 (STC 33)
 10 mm Tempered
 (STC 33)



Cover Finish
 - Aluminium Natural
 Anodize
 - Aluminium Powder
 Coating



Weight Approximately
 8 mm = 24 kg/m²
 10 mm = 30 kg/m²

STACKING METHODS



ORDINARY STACKING

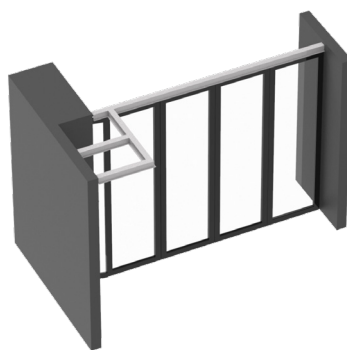

INDUCTION STACKING



PARALLEL STACKING



ORDINARY R-TYPE SYSTEM



CENTER STACKING
WITH TWO RUNNERS

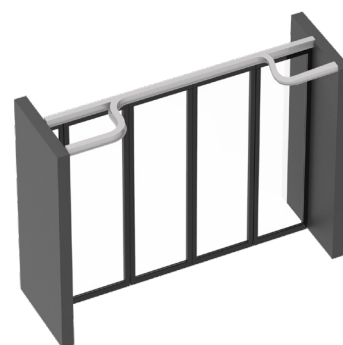

DOUBLE STACKING

FOLDING METHODS

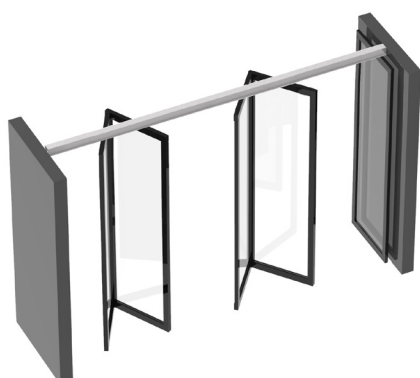

PAIRED SYSTEM



FOLD SIDE 4+1

STACKING AREA OPTIONS

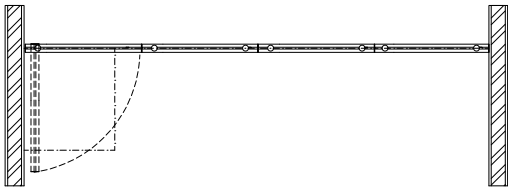

Ordinary stacking
Cross type system

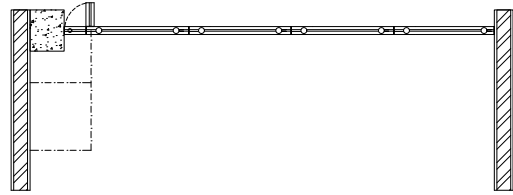

Induction stacking
Cross type system

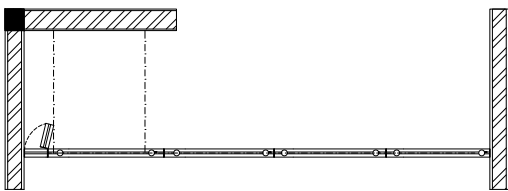

Parallel stacking
Cross type system

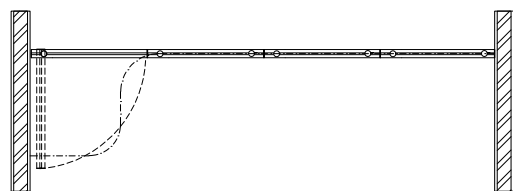

Ordinary stacking
R-Type system

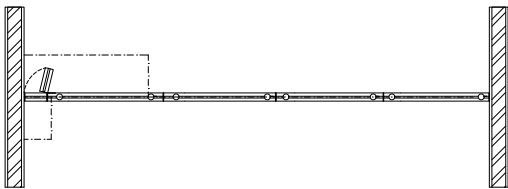

Center stacking 2 runners
Cross type system

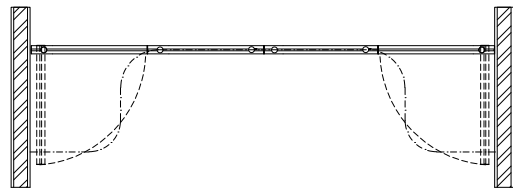

Double Stacking
R-Type system

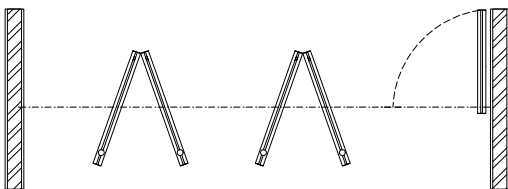

Paired system
Cross type system

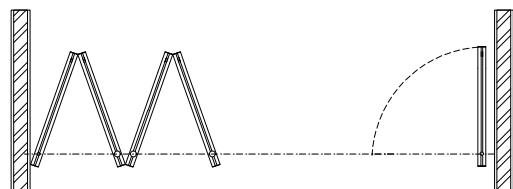

Fold side 4 + 1
R-Type system

SECTION DRAWING

SECTION DRAWING STACKING SYSTEM

VERTICAL SECTION HORIZONTAL FRAME

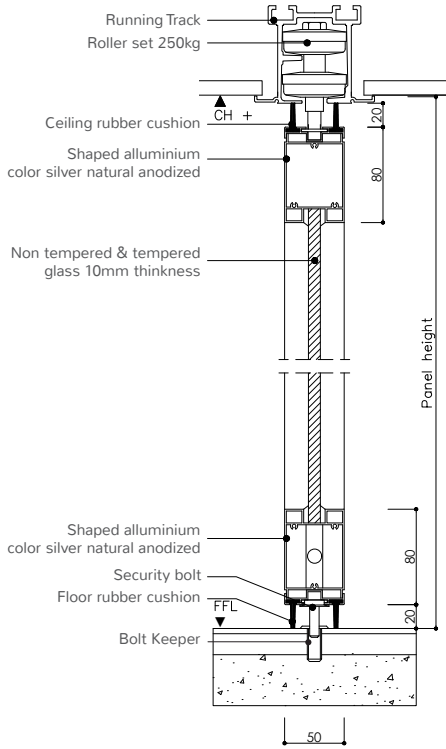

PERSPECTIVE ORDINARY STACKING

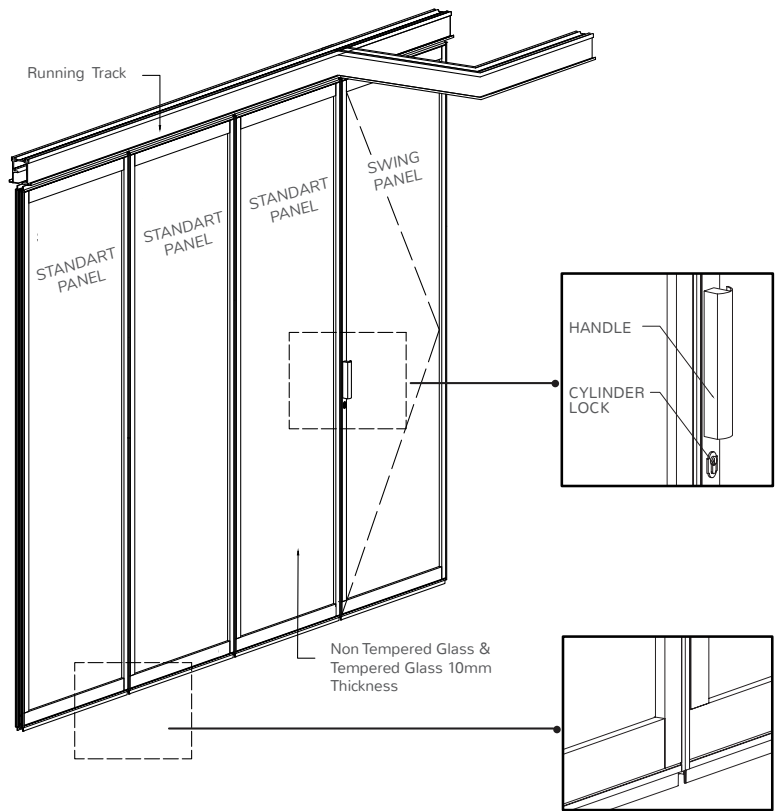

FOLDING SYSTEM

SECTION DRAWING FOLDING SYSTEM

VERTICAL SECTION HORIZONTAL FRAME

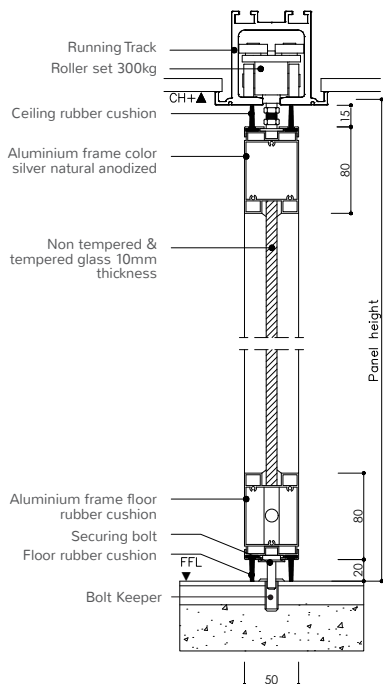

PERSPECTIVE PAIRED STACKING

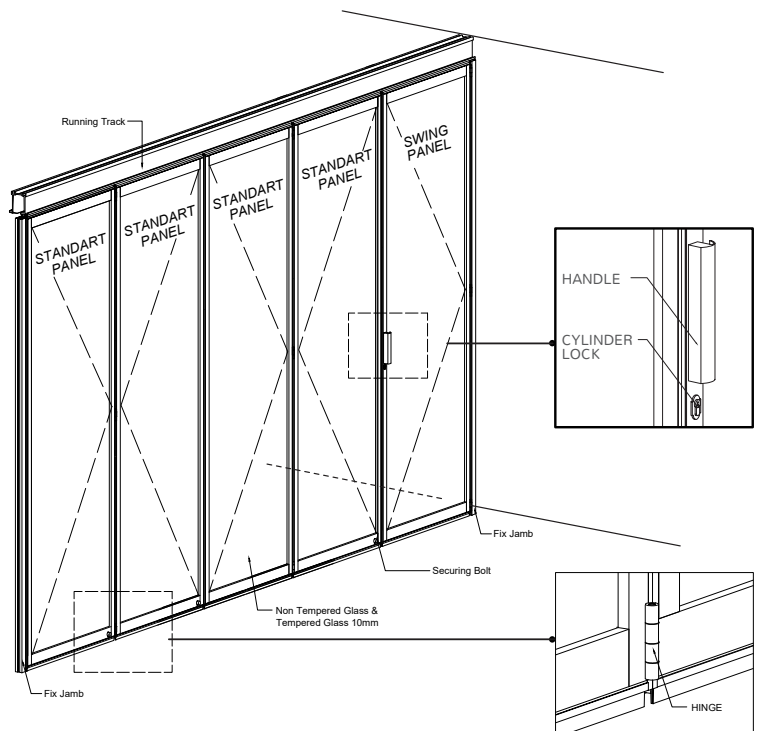

CONSTRUCTION SUPPORT

FOR STACKING AND FOLDING SYSTEMS

CONCRETE

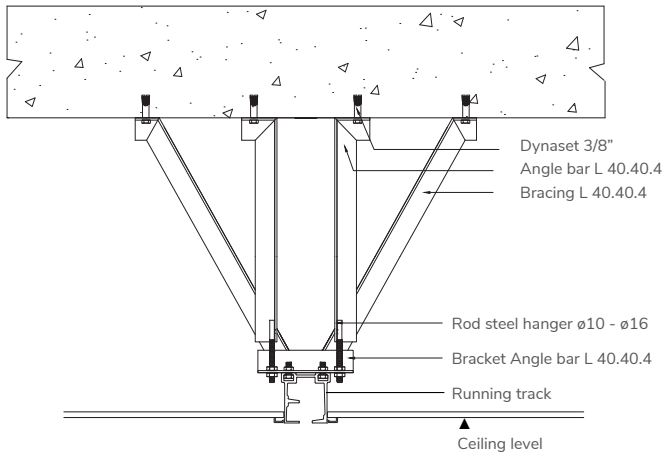

NON CONCRETE

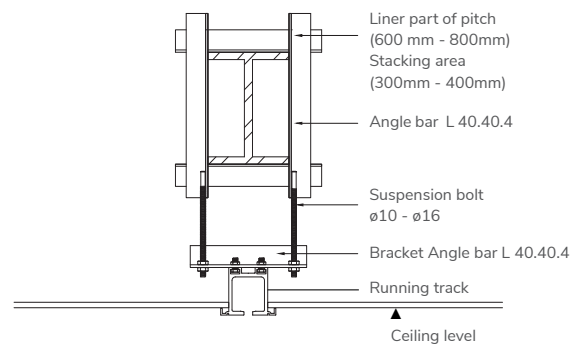

ACCESSORIES STANDARD

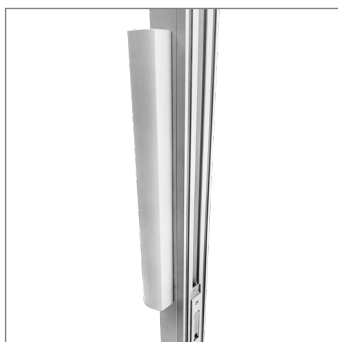

Handle

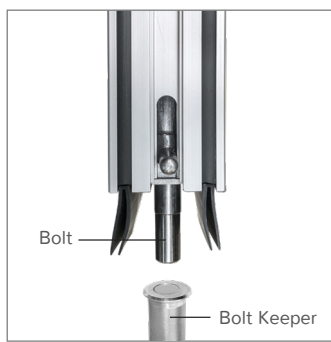

Bolt Set



Cylinder Lock

SPECIFICATION OF RAILS & RUNNERS

CROSS TYPE

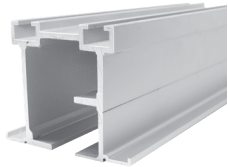
| TYPE | MATERIAL | IMAGE | |
|--------|---|---|---|
| 200 Kg | <p>Running Track Aluminium anodized H - base 3 - 5 thk</p> <p>Roller Set Base : MC Blue Bearing : Ø32- 2 pcs H. Density PTFE - Bearing Cover : Ø51 - 2 pcs Hanger Bolt : Based Ring Steel Ø12</p> | Roller Set | Running Track |
| | |  |  |

| | | | |
|--------|---|---|---|
| 300 Kg | <p>Running Track Aluminium anodized H - base 3 - 5 thk</p> <p>Roller Set Base : MC Blue Bearing : Ø40- 2 pcs H. Density PTFE - Bearing Cover : Ø65- 2 pcs Hanger Bolt : Steel Ø14</p> | Roller Set | Running Track |
| | |  |  |

R - TYPE

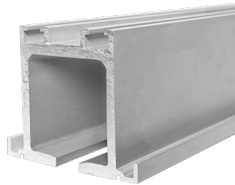
| TYPE | MATERIAL | IMAGE | |
|--------|--|---|---|
| 300 Kg | <p>Running Track Aluminium anodized H - base 6 thk</p> <p>Roller Set Base : Steel Bearing : Ø35 - 4 pcs Ø52 - 4 pcs Hanger Bolt : Based Ring Steel Ø16</p> | Roller Set | Running Track |
| | |  |  |



www.sandei.co.id

 sandei_official



Visit Our Website