

FRAMELESS

—
OPERABLE
GLASS

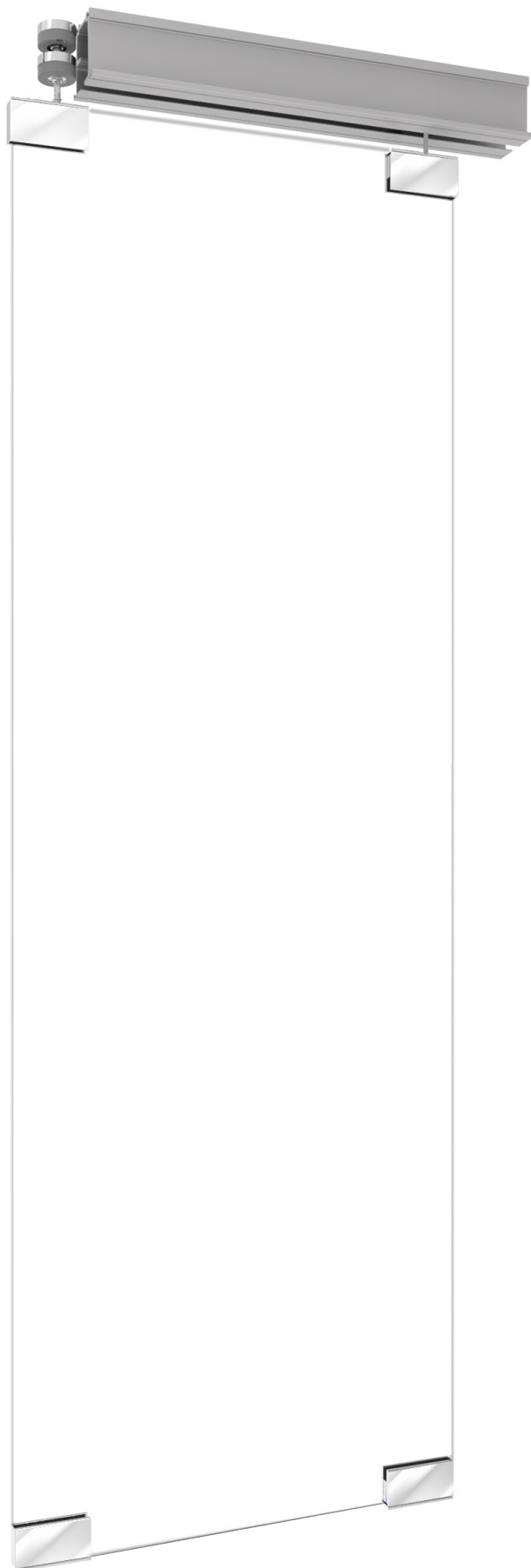



DETAIL SPECIFICATION

Operation Methods		Maximum Size	
		Width	Height
Stacking System			
Ordinary	✓	1200 mm	4000 mm
Parallel	✓		
Induction	✓		
Center	✓		
Folding			
Fold side	✓	800 mm	3500 mm



Glass Thickness
12 mm Tempered
(STC 28)



Weight Approximately
36 kg/m²



Cover Finish

- Stainless 304
Upgrade to 316
- Aluminium Natural
Anodized
- Aluminium Powder
Coating

STACKING METHODS

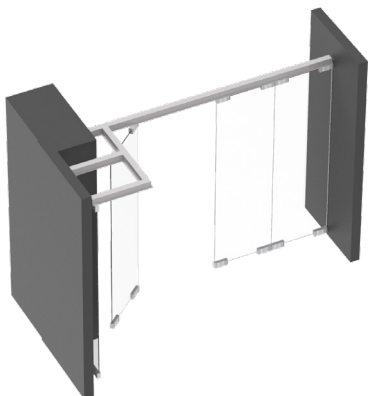

INDUCTION
CROSS TYPE SYSTEM

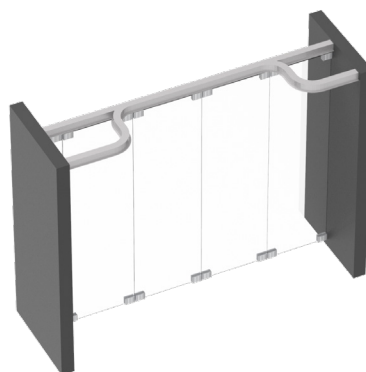

DOUBLE STACKING

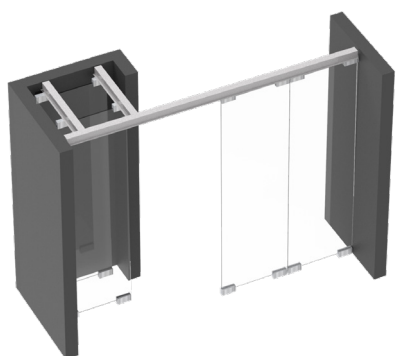

PARALLEL STACKING

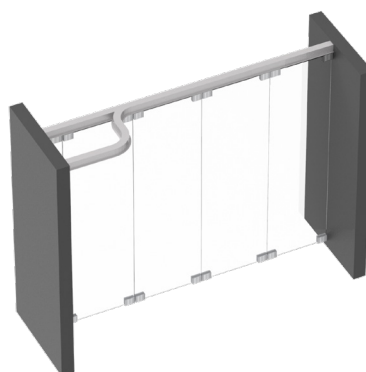

ORDINARY R-TYPE SYSTEM

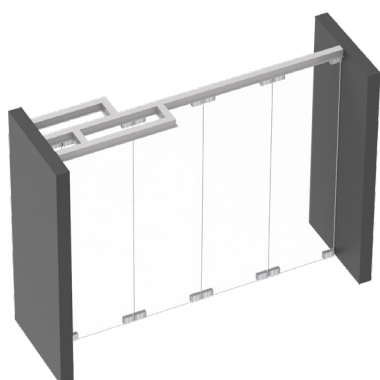

CENTER STACKING
WITH TWO RUNNERS

FOLDING METHODS

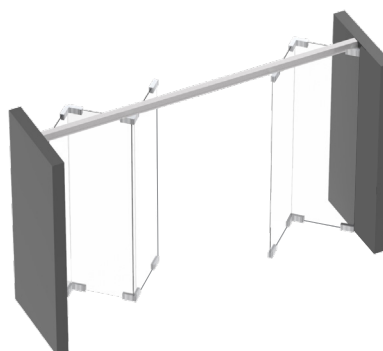

FOLD SIDE 3+2

STACKING AREA OPTIONS

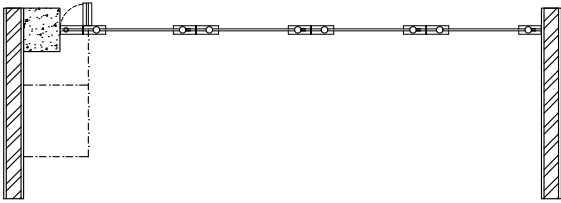

Induction stacking
Cross type system

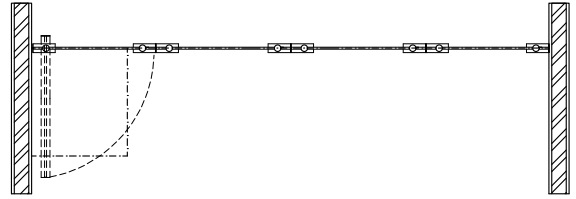

Ordinary stacking
Cross type system

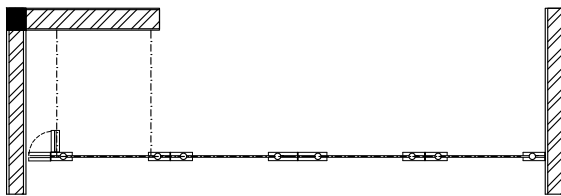

Parallel stacking
Cross type system

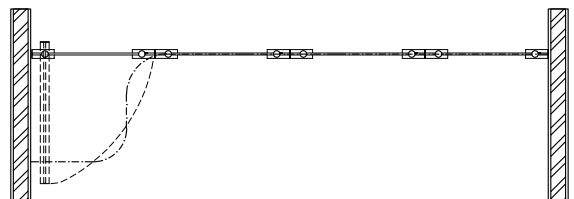

Ordinary stacking
R-Type system

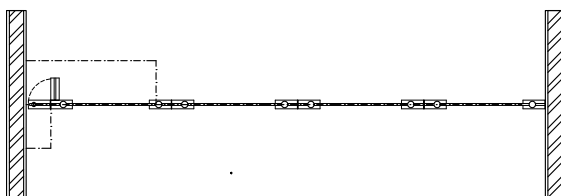

Center stacking 2 runners
Cross type system

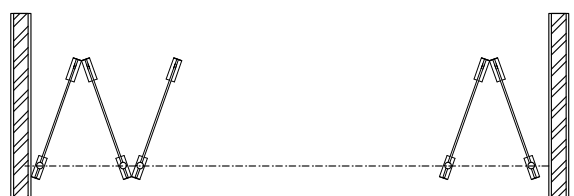

Fold side 3 + 2
R-Type system

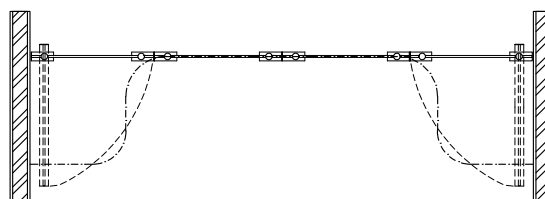

Double Stacking
R-Type system

SECTION DRAWING

SECTION DRAWING STACKING SYSTEM

VERTICAL SECTION HORIZONTAL FRAME

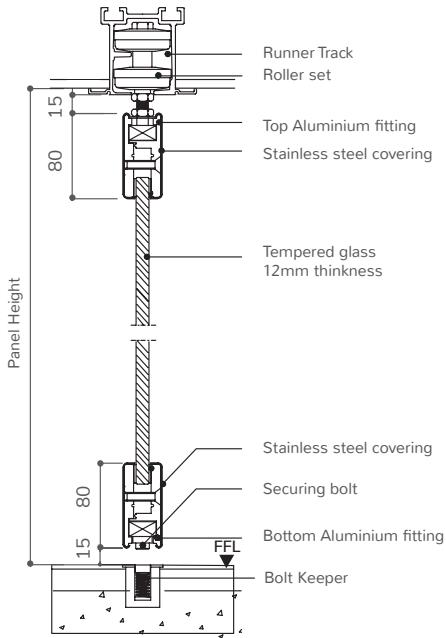

PERSPECTIVE ORDINARY CROSS TYPE SYSTEM

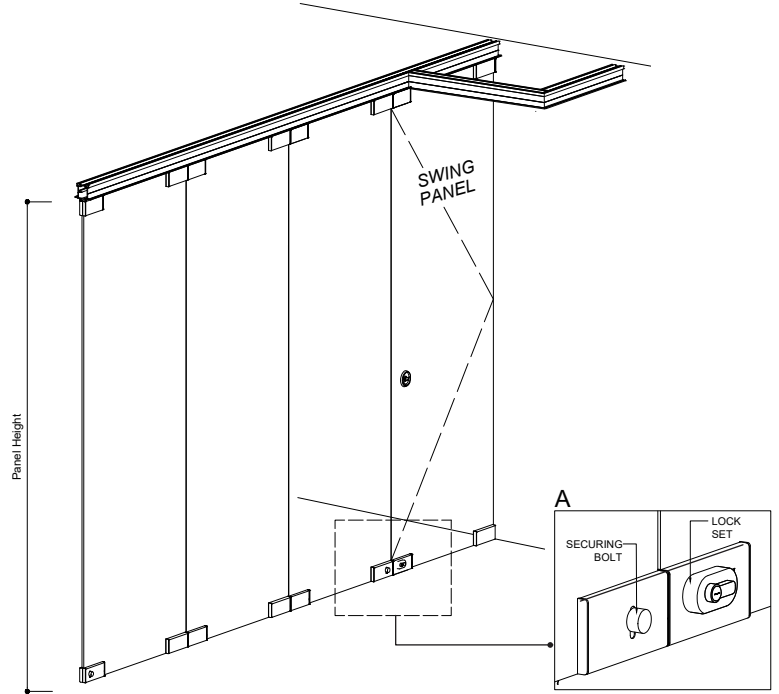

FOLDING SYSTEM

SECTION DRAWING FOLDING SYSTEM

VERTICAL SECTION HORIZONTAL FRAME

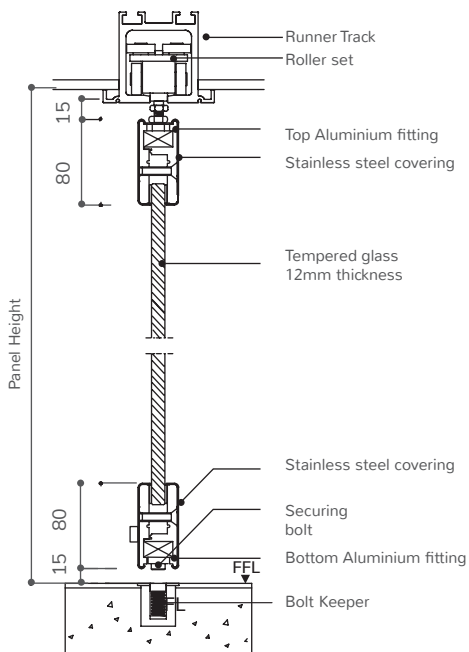

PERSPECTIVE ORDINARY STACKING R-TYPE SYSTEM

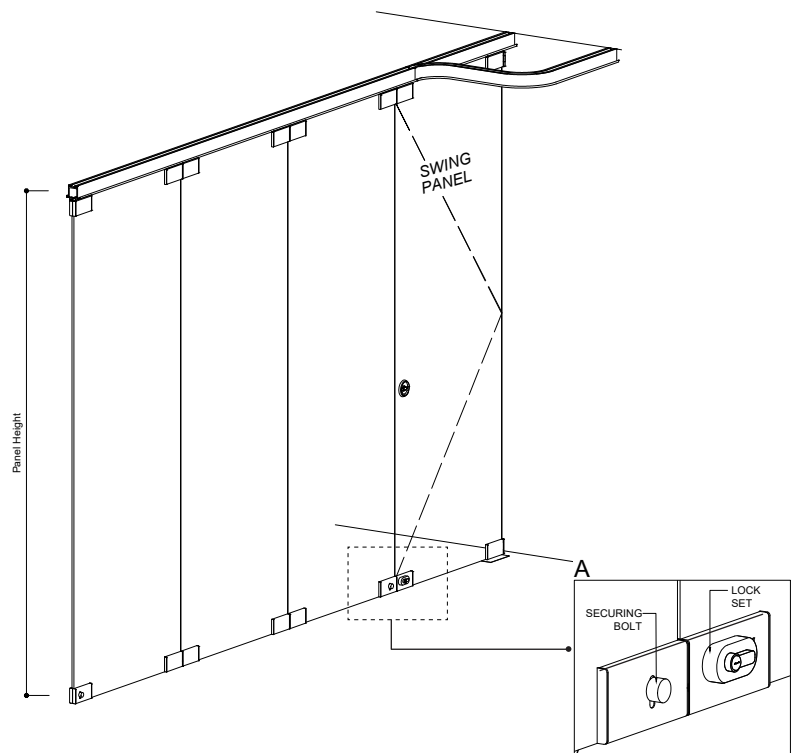

CONSTRUCTION SUPPORT

FOR STACKING AND FOLDING SYSTEMS

CONCRETE

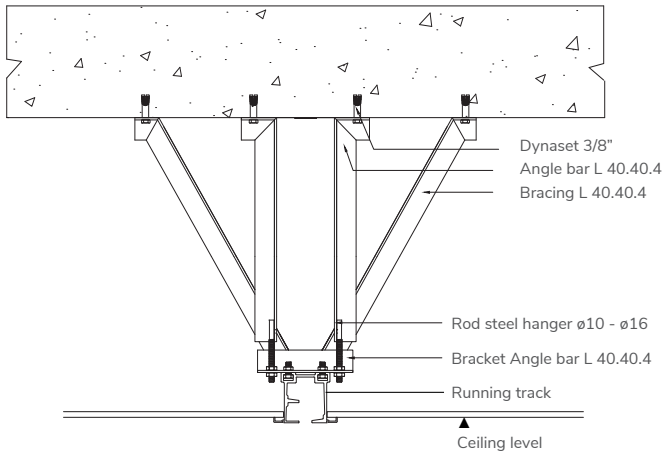

NON CONCRETE

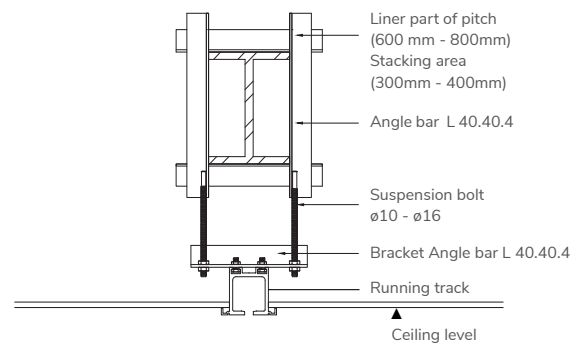

ACCESSORIES STANDARD



Handle

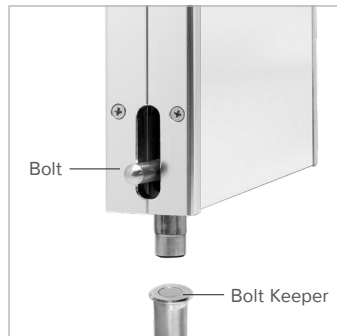

Bolt Set

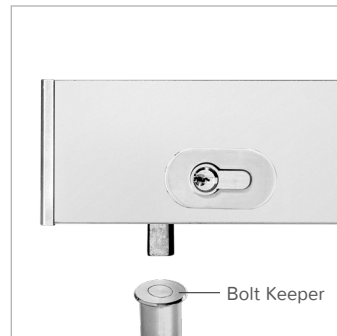



Lock Set



Clip Seal

SPECIFICATION OF RAILS & RUNNERS

CROSS TYPE

TYPE	MATERIAL	IMAGE	
200 Kg	<p>Running Track Aluminium anodized H - base 3 - 5 thk</p> <p>Roller Set Base : MC Blue Bearing : Ø32- 2 pcs H. Density PTFE - Bearing Cover : Ø51 - 2 pcs Hanger Bolt : Based Ring Steel Ø12</p>	<p>Roller Set</p> 	<p>Running Track</p> 

300 Kg	<p>Running Track Aluminium anodized H - base 3 - 5 thk</p> <p>Roller Set Base : MC Blue Bearing : Ø40- 2 pcs H. Density PTFE - Bearing Cover : Ø65- 2 pcs Hanger Bolt : Steel Ø14</p>	<p>Roller Set</p> 	<p>Running Track</p> 
--------	---	--	---

R - TYPE

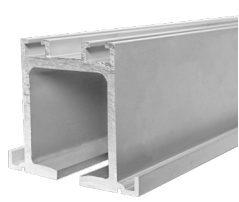
TYPE	MATERIAL	IMAGE	
300 Kg	<p>Running Track Aluminium anodized H - base 6 thk</p> <p>Roller Set Base : Steel Bearing : Ø35 - 4 pcs Ø52 - 4 pcs Hanger Bolt : Based Ring Steel Ø16</p>	<p>Roller Set</p> 	<p>Running Track</p> 



www.sandei.co.id

 sandei_official



Visit Our Website